



SALES POLICY



TABLE OF CONTENTS

To navigate through the manual quickly, click on the subjects to get you where you'd like to be!

PROGRAMS	3	CONNECTORS	14
PROGRAM NOTES	3	VHF/CONNECTOR TO PANEL DROP	14
STOCKING DEALER PROGRAM	3	COH/PANEL TO PANEL DROP	14
MOD. WALLS & TILE	4	PAINT CHARGES	15
MODULAR WALLS	4	PAINT NOTES	15
SIGNATURE CLASS	4	PEDESTAL & LATERAL PAINT SET UP FEES	15
V1 RAILS/V2 POWER/		WALL TRACK.....	15
ALUMINUM TOP CAPS	4	WORK SURFACES	16
CEILING CHANNEL PARTS.....	4	WORK SURFACE PARTS	17
OPS2 TILE SYSTEM	4	CANTILEVERS.....	17
GLASS OPTIONS.....	4	GROMMETS AND DATA PORTS (FLPDM)	17
LAMINATE TILE OPTIONS	4	LAMINATES - CUSTOM EDGE	17
STANDARD TILE CONFIGURATION	4	SELF EDGING	17
PEDESTAL SEAT CUSHION	4	CUSTOM EDGING.....	17
PANELS	5	PROCESSING EDGE BAND/	
CUSTOM SIZES	5	T-MOLD ORDERS	17
LAMINATE PANELS & TILE	5	GRAINS/LAMINATE	18
ACOUSTIC PANELS	5	WOOD GRAIN WORKSURFACES	18
TACKABLE PANELS	5	FLIPPER DOOR LAMINATES	18
PARTIAL GLAZED PANELS	6	SHELVES	18
FULLY GLAZED PANELS	6	DISPLAY SHELVES	18
OPEN FRAME PANELS	6	EDP SHELVES	18
PANEL PARTS	6	KEYS	19
ELECTRICAL ACCESS PANELS	6	SEATING DISCOUNTS	19
STACKERS	7	KEYS	19
STACK GLASS & GLASS FRAME OPTIONS ..	7	FLIPPER DOOR KEY ALIKE PROCEDURE	19
STACK GLASS UPCHARGES	7	ORDER ENTRY/CSR	19
STACK GLASS UPCHARGES	8	PRODUCTION	19
MARKER BOARD STACKERS/		KEY EXAMPLE	20
FABRIC STACKERS	8	SEATING	22
MULLIONS	9	SEATING DISCOUNTS	22
PGH/MULLIONS	9	ORDER INFO	23
MULLIONS	9	APPROVAL PROCESS	23
DOORS & DATA	10	AS IS PRODUCT.....	23
DOORS	10	TRIM REPLACEMENT	23
DATA AND RECEPTACLE		CANCELLATION POLICY	23
PUNCH OUTS FOR PANELS	10	STEPS FOR CANCELING	
FABRICS	11	A SALES ORDER:	23
COM (CUSTOMER'S OWN MATERIAL) ..	11	CUSTOMER PICK-UPS	24
FABRIC UPCHARGES	11	SHIPPING	25
MULTIPLE FABRICS, PAINTS		SHIPPING FEES	25
OR LAMINATES.....	11	TIMED/SCHEDULED DELIVERY POLICY	25
MOCK-UPS	12	ESTIMATED SHIPPING SCHEDULE	26
ELECTRICAL	13	OVERNIGHT REQUEST:	26
FESTOON 19 & 23	13	STORAGE FEES	26
PEKS.....	13	SHIPPING FORM	27
POWER POLES	13		
V1 & V2 POWER	13		



PROGRAM NOTES

1. All systems orders that do not contain panels fall under the Signature Class and should be classified as Signature in the header of the order.
2. If there are panels on the order, then the fabric drives the class but fabric alone does not determine the class. Other specifications must fall under the program to receive the program discount.
3. Chairs and Casegoods fall under the Signature Class.
4. We are now painting the slot channels on panels when the finish is other than BU so they will match other Signature panels.
5. Kitting and manufacturing are trained to pull the correct rails based on class. Even though they have paperwork on what to pull it is confusing when exceptions are made.
6. V1 power can be used on Signature panels as an exception but we prefer to stay away from V2 power being used on Sustainable C2 panels. We pay more for the V2 power and that is part of the reason to go to Signature.

STOCKING DEALER PROGRAM

- Stock program using OPS Pebble Creek or Grey Sky.
- Initial order \$30,000 net
 - Terms of 1/3 - 60, 1/3 90 days
 - Order must be marked for stock and not intended for project business.
- \$10,000 fill in orders
 - Net 45 days, order must be marked for stock and not intended for project business.
- Discount used is the C2 - 10 week program pricing but delivered in 3 weeks.
- Finish and work surface options under Sustainable C2 Program

ADDITIONAL PLATINUM/GOLD PLUS DEALER BENEFITS

Timed Delivery: **Waived**

Waived on orders of 50K or above.

*Forms must still be completed in order for base insurance coverage.

Revisions: **Waived**

Once an order has been approved, a \$50 administrative fee will be charged for revisions made after 48 hours. Revisions on 5 business day Lightning Program are not allowed. Standard terms still apply.

Rush Orders: **Waived**

All rush orders are based on approval and shipping can be improved from 2 weeks to 1 week or from 3 weeks to 2 weeks for an additional charge of 5% of order net price at a minimum charge of \$25.

Call Ahead Fees: **Waived**

Paint Set-up Fees: **Waived**

Waive paint set up fees DT, FG, LG, HT, LU, JT

*Storage paint fee still applies due to labor.

MOD. WALLS & TILE



MODULAR WALLS

SIGNATURE CLASS

- Includes standard panels > 85H or may be combined with fabric or glass stackers in order to reach 107H. See modular walls flyer.
- Clear stackers are tempered and requires the customer's approval. Bronze, Smoked, and Frosted stackers are plexiglass and receive an upcharge. (See Stacker Section for upcharges)
- Acoustic panels are available and a stacker can be made acoustic if requested for a 5% discount reduction.

V1 RAILS / V2 POWER / ALUMINUM TOP CAPS

- If the customer is matching existing V2 rails we can paint the V1 rails to match.

CEILING CHANNEL PARTS

- Ceiling trim pieces can be painted. Paint colors are not set up in Epicor and will need to be added to the SKU.
- SKU CT.CEILING CHANNEL automatically comes with 4 clips, channel trim and hanger

OPS2 TILE SYSTEM

GLASS OPTIONS

- **Clear:** Tempered Glass – no upcharge
- **Bronze/Smoked:** Plexiglass only – \$14.00 upcharge
- **Frosted:** Plexiglass only –\$28.00 upcharge

LAMINATE TILE OPTIONS AT NO ADDITIONAL CHARGE

- BU, WF, Shadow Ridge & Empire Mahogany
- If non-standard laminate is requested, must get quote from purchasing.

STANDARD TILE CONFIGURATION

- Bottom is perforated metal – if customer wants fabric, laminate or Open it must be noted.
- Reveal Bar is used with all tiles

PEDESTAL SEAT CUSHION

- Budget mobile Ped is the only one that can use a cushion and still fit under a work surface for seat cushion, must be noted in the line comment.
 - Sku#:
 - **SC-MPB:** Seat cushion for budget mobile ped
 - **SC-FP-MP:** Seat Cushion for full pull mobile ped
 - **SC-SP-MP:** Seat Cushion for square pull mobile ped

PANELS

CUSTOM SIZE: Due to insurance liability, OPS will not alter panel heights and widths



LAMINATE PANELS & TILE

- Ships in 3 weeks.
- Available in Signature Program only.
- As a standard we will carry Black Umber, Empire Mahogany, White Frost, and Shadow Ridge for our Panel & Tile Laminate Options. If we use laminate Tile no additional upcharges are needed, but if an AO2 panel is quoted a 2% discount reduction is required.
- Laminate cannot be set on acoustic panels. Panels must be fabric base; therefore, use a fabric panel sku # for example item # F4730
- Laminate panels can not be set in a 60" width – must use two 30" width panels and a panel to panel connector in order to obtain the 60". This is due to the dimensions of the laminate and challenges to production, shipping and installing.
- If Wilsonart, Formica, Nevamar, or Pionite laminates are used, we can use 60" wide panels with approval from John Wood. Non-standard options will need to be quoted on a case by case basis and will receive a 4% discount reduction for any non-standard color option, allow a 4 week lead time. Purchasing will advise if there is an issue.

ACOUSTIC PANELS AVAILABLE IN ALL PROGRAMS

- If 39"high or 47"high acoustic panels are requested this would be a custom part number and must be reviewed with purchasing prior to quoting. Use part number A39## for 39"high or A47## for 47"high. Lead Time is 4 weeks- use List Price of 53"H.
- 39"high and 47"high acoustic panels are priced the same as 53"high acoustic panels. Enter the A53 high panel for pricing & then adjust part number and description to show correct height needed. Please follow Custom Part Entry policy when creating quote or order.

TACKABLE PANELS AVAILABLE IN ALL PROGRAMS EXCEPT QS AND LIGHTNING

- Tackable panels have their own part numbers and are offered in AO2 heights from 53"H to 85"H; and in widths from 24" to 48".
- We do not offer 12", 18", or 60" tackable panels widths.
- Only the top section of a panel is tackable (not the whole panel). Review with purchasing for exact measurement.
- We do not offer Acoustic Tackable panels.
- If 39" high or 47" high is requested this would be a custom part number and must be reviewed with purchasing prior to quoting. Use part number FT39## for 39"high and FT47## for 47"high tackable panels. 39"high and 47" high Tackable Panels are priced the same as 53"high Tackable Panels. Enter a FT53 high panel for pricing and then adjust part number and description to show correct height needed. There will be a 4 week lead time.
- Please follow Custom Part Entry policy when creating quote or order.
- Not offered on Quickship.

PARTIAL GLAZED PANELS SIGNATURE PROGRAM ONLY

- Partial Glaze are manufactured using Plexiglas; Tempered Glass Not Available.
- Minimum lead time is 3 weeks.
- A line comment is needed when using Smoked, Bronze, or Frosted
 - **Bronze or Smoked Partial Glaze Panels (regardless of height or width):**
 - Net charge \$30.00 per panel
 - **Frosted Glass Partial Glaze Panels (regardless of height or width):**

PANELS

- Net charge \$60.00 per panel



FULLY GLAZED PANELS SIGNATURE PROGRAM ONLY

- Full Glaze are manufactured using Plexiglas; Tempered Glass Not Available.
- Minimum lead time is 3 weeks
- Upcharge note must be shown on each line that it applies to:
 - **Bronze or Smoked Full Glazed Panels (Regardless of height or width):**
 - Net charge \$30.00 per panel
 - **Frosted Full Glaze Panels (Regardless of height or width):**
 - Net charge \$70.00 per panel

OPEN FRAME PANELS SIGNATURE PROGRAM ONLY

- Offered in 67" and 85"H only

PANEL PARTS ONLY

- When selling parts only (e.g. V2 rails, base covers, etc.), if the quantity is over 25 we need to have Dean approve.

ELECTRICAL ACCESS PANEL ONLY AVAILABLE ON FABRIC PANELS & NOT AVAILABLE ON QS

- If a panel needs an electrical access cut out, then add a line comment "TO RECEIVE ELECTRICAL ACCESS"
- There is a \$25.00 net each fee to have the electric access cut out. This fee is applied in the miscellaneous line charges and applies to each panel requiring a cutout.
- Electrical access cut outs are only available on fabric panels.
- Electrical access panels have a minimum of a 3 week lead time. The product is shipped from Canada.

RAZOR THIN BASE OPTION

- When using our Razor Thin Base Option, you have to follow the below for quoting proper 2, 3 and 4 way connectors as well as festoons
- Receptacle covers must be specified as RECCOPCOV.T.COLOR

PART #'S TO USE

2WYXXA2.T.PAINT.BASE
 3WYXXA2.T.PAINT.BASE
 4WYXXA2.T.PAINT
 ECXXA2.T.PAINT.BASE
 REC/ X.T.BASE
 FESTOON 19
 FESTOON 22
 FESTOON 23
 (CF2 AND CF4 DO NOT CHANGE)
 ALWAYS V1 POWER W/ THIN BASE
 * CANNOT PROVIDE DOORS W/ THIN BASE
 SPACEXXA2.T.PAINT.BASE

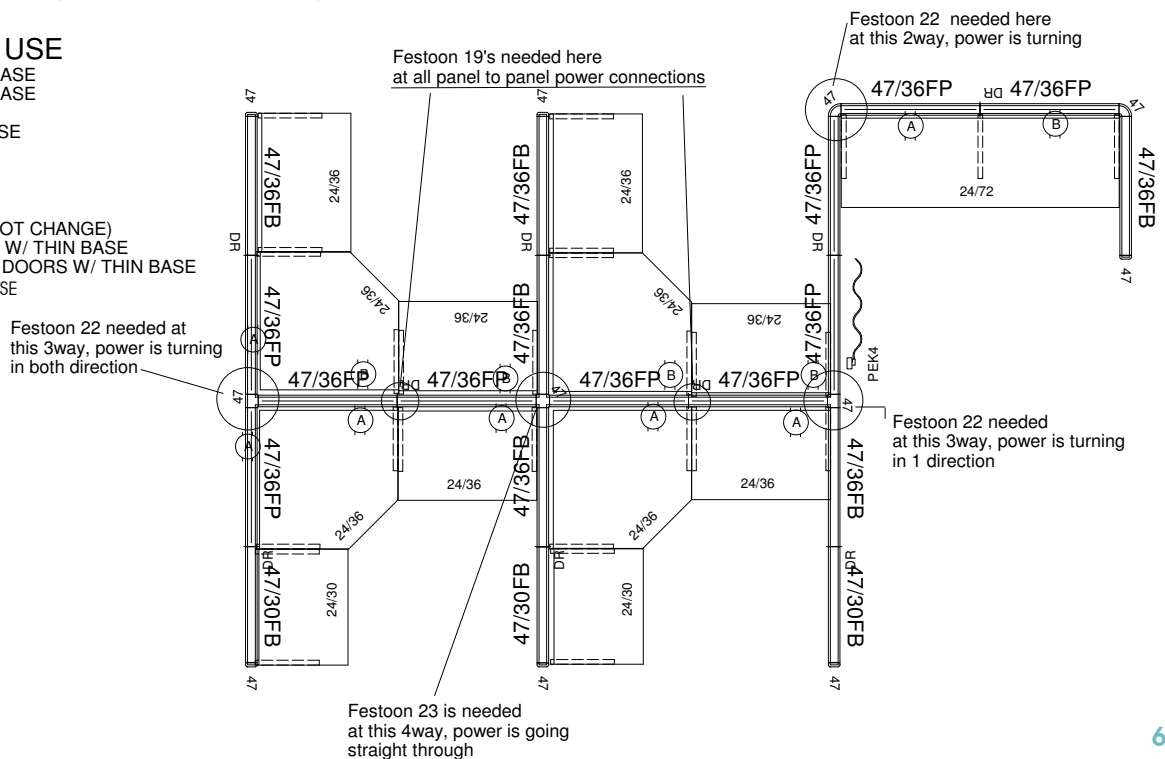

STACKERS

- Partial Glazed Stacker SKU#'s are used instead of an individual panel SKU and glass stacker SKU. Regular glass stackers are still available but pricing has not been reduced for these. (i.e. cheaper to use the PGS SKU)
- A note must be applied to each panel receiving a stacker is not using new PGSF Sku's.



STACK GLASS & GLASS FRAME OPTIONS

1. Stack glass panels include tempered glass and come in heights of 14", 18", 20" and 22"
2. 22" glass stackers are only available in the modular wall height.
3. Glass stackers - do not require top caps, they are built in the frame.
 - 3.1 If using glass stackers w/ V1 rails – a note must be added (include machine screws)
 - 3.2 If using glass stackers w/ V2 rails – no note is needed.
 - 3.3 Light shield tape is required for fabric stacker. For add-ons, put note on "SF" line to send.
 - 3.4 PNL Wedge Blocks are needed with V1 rails only, not V2. If customer has existing panel wedge blocks and does not need to order any, then apply a note to comments advising; otherwise if there is no note, then they should be a billable item.

STACK GLASS UPCHARGES

1. For all glass stackers (14", 18", 20" & 22"), sold individually or with the new PGS sku, the NET upcharge cost per panel below applies.
2. A line comment is needed using Smoked, Bronze or Frosted Glass
 - **Bronze or Smoked:** Net charge of \$14.00 per stacker
 - **Frosted:** Net charge of \$28.00 per stacker

STACKER NOTES FOR INSTALLING STACKERS TO EXISTING PRODUCTS

1. We need to ask the customer if they have V1 or V2 rails in the field before we can quote.
2. Acoustic Stacker - a stacker can be made acoustic if requested for a 5% up-charge (included in price in Epicor)
3. Glass stackers - do not require top caps, they are built in the frame.
 - 3.1 If using glass stackers w/ V1 rails – a note must be added (include machine screws)
 - 3.2 If using glass stackers w/ V2 rails – no note is needed.
 - 3.3 Light shield tape is required for fabric stacker. For add-ons, put note on "SF" line to send.
 - 3.4 PNL Wedge Blocks are needed with V1 rails only and not V2. If customer has existing panel wedge blocks and does not need to order any, then apply a note to comments advising; otherwise if there is no note, then they should be a billable item.

STACKERS



MARKER BOARD STACKERS/FABRIC STACKERS

The Standard Marker Board has marker board material on one side. If the customer wants marker board material on both sides then the discount would be reduced by 2% and a note must be added to the stacker line "Double side marker board"

Fabric stackers – will always require a top cap. It does not matter whether it is on the very top or in between other stackers. This is needed to fill the space between them.

1. We do not recommend re using existing top caps because they are normally damaged when they are pulled off.
2. We need to always spec top caps w/ fabric stacker parts.
3. You will need to review and confirm if a metal or plastic top cap is needed.

MULLIONS

PGH/MULLIONS

MULLIONS

- 14" High will be our standard height and what will be displayed in Giza. Any height above 14" would be considered a custom and a 25% upcharge will apply. (MUST BE APPROVED BY PRODUCTION) Mullions are offered in fabric, plexiglass and tempered glass
 - **Bronzed or Smoked:** Net charge of \$23.00 per mullion - plexiglass only



FROSTED TEMPERED GLASS PGHM MULLIONS

- Note: 24", 30", 36", 42" and 48"w mullions come with two PGHM's
- 60" and 72"w mullions come with four PGHM's



OUTSIDE VIEW- PGHM SPANNING TWO PANELS

- Note: If using one tempered glass mullion to span two panels, panels must be the same width due to pre-drilled holes in mullion
(plexi can be used on two different size panels because they do not have pre-drilled holes)

DOORS & DATA

DOORS

- Our doors come in our (5) standard paint colors
- For a 2% up-charge, a customer can choose one of our standard 14 laminates. If a different laminate is requested the lead time would become 4 weeks and a 4% up-charge would apply.
 - **Sidelight:** Standard door w/ glass sidelight the glass is clear. A line comment and line charge are needed
 - **Bronzed/Smoked:** NET CHARGE \$18.00 PER DOOR
 - **Frosted:** NET CHARGE \$31.00 PER DOOR

NOTE: FOR A FULL PLEXI-GLASS DOOR YOU WOULD NEED TO CHANGE THE STANDARD DOORPNL85.(COLOR). SKU TO INCLUDE A "G" IN THE END TO SHOW UP ON WORK BENCH

- To do a full plexi-glass door there is a labor cut out fee of \$51.00 net per door (the standard cut out is 24" x 72" and this is shown on the showroom floor). The \$51.00 would be in addition to specific glass finish option chosen below. Put a G at the end of the part # but before the paint color (i.e. DOORPNL85L/R.G.Color)
 - **Clear:** NET CHARGE \$22.00 PER DOOR + \$51.00 CUT FEE
 - **Bronzed/Smoked:** NET CHARGE \$45.00 PER DOOR+ \$51.00 CUT FEE
 - **Frosted:** Net CHARGE \$78.00 PER DOOR+ \$51.00 CUT FEE
 - **Striped Glass:** Not an option

NOTE: We no longer carry the AO1 door.

DATA AND RECEPTACLE PUNCH OUTS FOR PANELS

- Use the following skus:
 - **For Receptacle (power) covers:** RECOPCOV.xx (color)
 - **For Data covers:** RECOPCOVDATA.xx (color)

Note: These sku's and pricing includes the labor to cut the base covers.

- **Filler Plates:** If you just need the filler plates sent and we are not punching any of the panels, please add a note to the cover sku line "SEND COVERS ONLY".
- **Panel Punches:** If you need some panels to be punched, please mark the quantity and add a line note on the panels line.
- **EXAMPLE:**
 - (20) F6730
 - (10) panels punched on 1 side/2 sides for V1 or V2 power
- **OR** your line comment could say:
 - (20) F6730
 - (10) panels punched for data on 1 side



FABRICS

FABRICS



COM (CUSTOMER'S OWN MATERIAL)

- Must be approved prior to order acceptance.
- The dealer is responsible for forwarding sample of COM material or non standard Fabric sample prior to application of fabric to the CSR
- When COM order is over 50 yards a credit of \$5.50 per yard is allowed on the order. Use discount as item number with an explanation.
- When entering an order that is all COM– enter COM in front of fabric name and number in the order header. Instruct the dealer to send COM fabric to us marked ATTN: John Wood and reference the sales order number. A note should be applied to the sales order (ship date will be based on arrival of COM fabric).
- Request tracking info

FABRIC UPCHARGES

- Refer to fabric upcharge sheet for per yard cost and roll cost
- Add fabric upcharge to order as a miscellaneous fabric upcharge
- CF Stinson Fabric Upcharge: Cross reference Guildford or Burch Fabric pricing from the intranet, find a fabric that is closest in price and then refer to the fabric upcharge by yardage list to compare and provide adequate pricing

MULTIPLE FABRICS, PAINTS OR LAMINATES

- Orders with multiple specifications should be listed as "See Below" in header and detailed on the corresponding sale item line.
- When directional line comments are necessary for fabric, use the industry terms Railroad or Directional so there is no confusion as to how the fabric is to be placed.

Note:

- **OPS Sand gathers on Acoustic so Broadcast Serengeti is recommended instead.**
- **GF Rattan is not offered on the file system.**
- **Columbus fabric should not be used on Acoustic panels due to gathering.**

MOCK-UPS

MOCK-UPS

- Display or mock ups may be purchased by all dealers at the normal program discount plus an additional 50%. Standard lead time and freight charges apply.
- Stock Chairs and Caseloads are available for display at normal program discount plus an additional 25%.
- Products purchased to use as offices for a dealer are subject to an additional 25% from the normal program discount.
- Normal freight terms apply.
- At OPS option we are willing to provide at no charge to our Platinum, Gold and probationary Gold dealers the following:
 - Signature display/design created by OPS
 - OPS seating samples: 4008 and B3
 - Hampton Espresso desk or similar item
 - Product will be sold to OPS and shipped to the dealer at no charge. Ownership of the product will belong to OPS, the product is subject to upgrading, replacing or being returned at OPS' sole discretion based on the sales achieved by the dealer.
- Standard Lead Times will apply; if a faster lead time is needed, approval will be required



ELECTRICAL

FESTOON 19 & 23

- The C2 and Quick Ship programs currently offer V1 rails and power. When this power needs to pass through a connector to reach the adjacent panel, then festoon 23s are used to provide an electrical extension.
 - At no additional cost to the customer
- A drawing is required to determine which panels need power to pass through the 3-way or 4-way connector
 - As a last resort, the quantity of festoon 23 's needed for the project can be based upon the number of 3 and 4-way connectors on the order.
- All orders with V1 power require Festoon 19s and are to be entered as a line item at no charge. The number of festoons entered must match the number of powered panels on the order.
- If festoon 23s are needed they are to be entered as a line item at no charge as well. The total number of festoon 23s and festoon 19s entered must equal the number of powered panels on the order.
- If there are 3-way and 4-way connectors on the order and no festoon 23s are needed, put a line comment on the festoon 19's
 - NO FESTOON 23s NEEDED.
- If a 2-way 120 degree connector is being used then a festoon 23 will be needed.

PEKS

- Occasionally PEKs need to be shipped before an order.
- If a customer requests to have the PEKs shipped early AND it is shipping to the same address then you can update the release tab with the earlier date and it can remain on the order.
- A line comment must be added and copied over to all tabs, to show this line is shipping early/ show the ship date.
 - If it is shipping to a different location then delete them from the sales order, generate a new order and add a line the in header comments on original order "PEKs PULLED EARLY TO SHIP ON ORDER # # # # #".

POWER POLES

- Ceiling Feed CF2 – excludes ceiling or base trim. Attach by dropping into a 3-way or 4- way SKU # CF23WY or CF24WY
- Ceiling Feed CF4 – includes a ceiling and trim. Attach by connecting pole hardware to panel or connector rail.
 - When ordering a CF4 add a line comment ## HIGH CONNECTION
- If a customer needs a CF4 shipped early, the complete, uncut unit will ship LTL for a minimum \$75 freight charge.
 - If the customer wants this sooner, advise them the only way it can ship UPS or FedEx is if the pole is cut in half.
 - They must agree to this before we will ship this way. Standard freight terms apply unless they are shipping on their account.
- When placing orders that contain only power (power poles, peks, harnesses) and no panels, the power must be listed in the header of the order.

V1 & V2 POWER

- Any order with V2 power must have the PEK4V2 specified.



CONNECTORS



VHF/CONNECTOR TO PANEL DROP

COH/PANEL TO PANEL DROP

NOTE: CSR's must revise COH SKU # to utilize correct size part.

- When there is a variance in height of panels at a connector, then please complete a VHF form located on the intranet.
- All VHF forms are to be attached to the Sales Order and saved in the VHF folder on the intranet. Add a line comment under the ordered VHF on the order "See Attached Form."
 - When the dealer does not provide a drawing, then add a line comment: "No form provided. Dealer is responsible for field installation."
- When there is a panel to panel change of height, add a line comment (under the panel that has the drop) the number of panels that will have one side dropped down.
 - No need for a line comment when using V2 rails.
- When a change of height is needed with multiple sizes: Add the product for a change of height using sku# COH(Height)V1.xx or COH(Height)V2.xx depending on rails used.

Qty	Item#	Description			List
10	F6736	67 X 36 FABRIC PANEL W/BASE	100.0%	P	\$659.00

- Instructions/Comments:
 - (3) Drop 1 side to 39
 - (2) Drop 1 side to 53
- There must be a line comment for COHV1 either on the panel as shown above or on the COHV1 "TO BE FIELD INSTALLED" if it is to be used for a parts order or in a reconfig.

NOTE: When doing a drop down with a counter cap, V1 rails must be used.

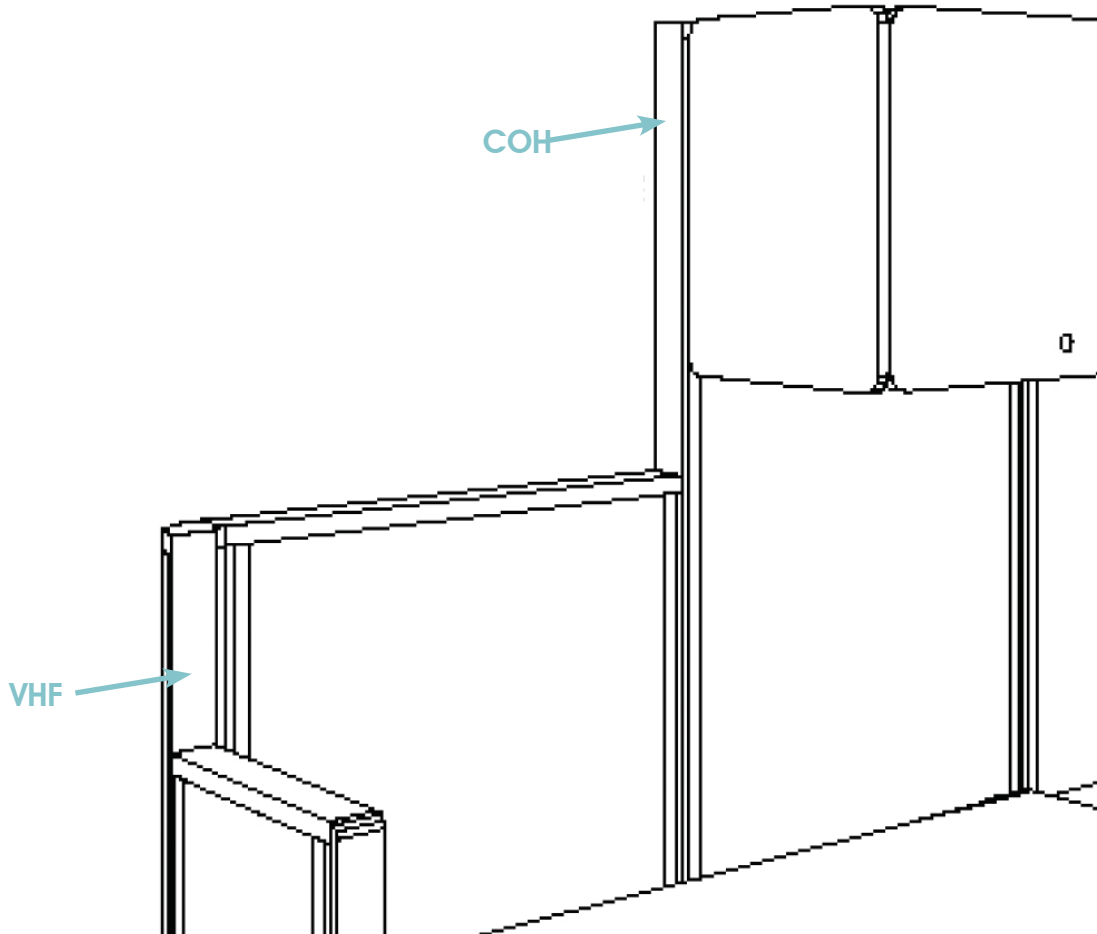

PAINT CHARGES



PAINT CHARGES

OPS Standard Colors: BU, HF, LT, WF and MT	Standard Pricing
Herman Miller Colors: JT, HT, LG, DT, and LU	\$25.00 set up fee for orders under \$500.00 \$150.00 set up fee for orders over \$500.00

- Apply Charge under the Header/Misc Charge
 - NOTE: *Any paint color not listed above will have a \$250.00 paint set up fee (plus the cost of paint) regardless of the job size. This fee will not be waived.**
- * Cost of paint will need to be checked by Ben Mitchell.
- OPS currently has existing product in DT. Calculate the DT paint fee based on the products that need to be painted and are not currently in our inventory.
 - See Dina Fink if you have any questions.

PAINT NOTES

- When an order is one color but some of the items on the order are a different color, please add a line comment and a comment in the header indicating the order contains items with different colors.
 - **EXAMPLE:** If a BBF-FP-MT pedestal is requested for a BU order, add a line note to that pedestal stating "MT PAINT IS CORRECT."

PEDESTAL AND LATERAL PAINT SET UP FEES

- Please refer to the "Pedestal Discounts" section for listing of standard colors.
 - A paint set-up fee (charged as a "new miscellaneous header charge") will be added for all nonstandard colors.

Pedestals	Add \$25.00 net paint fee
2 Drawer Lateral	Add \$25.00 net paint fee
3 Drawer Lateral	Add \$35.00 net paint fee
4 Drawer Lateral	Add \$45.00 net paint fee
5 Drawer Lateral	Add \$55.00 net paint fee
Wardrobe	Add \$55.00 net paint fee

WALL TRACK

- Non-painted is the standard for wall tracks.
 - Please use the .np SKU#. If the customer requests a color, then use the SKU# that indicates the proper color.
 - There will no additional paint fee when the customer requests to have it painted, as long as it is one of our standard colors.

WORK SURFACES

WORK SURFACES



Custom Laminate: Nevamar, Wilson Art (not hi-gloss) Arborite, Formica	2% Upcharge
Custom Laminate: Pionite – Wilson Art Hi Gloss – 35 & 45 Finish Wilson Art High Definition - 55 Finish	4% Upcharge
Laminate Waste Charge	Waste charges apply when using less than a 4' x 8' sheet. Subtract what is used from 32 sq. feet x \$3.00= waste fee. Add as a miscellaneous header charge.
Custom Cut Worksurface Charge	\$25.00 per custom cut. This fee would only apply for custom cuts that require a drawing for production. <ol style="list-style-type: none"> 1. Add fee as a miscellaneous header charge. 2. SAVE DRAWING TO CUSTOM CUT FOLDER ON WEB. 3. Make sure to apply line comments for custom cut worksurfaces and for grommet placement & cuts. 4. Check the form box so that production knows to look for the form on the server. 5. Also indicate if cantilevers are needed.
Pricing Without Cantilevers	Deduct \$8.00 per surface for new. Deduct \$5.00 per surface for as is.

NOTE: Any top made by OPS that is larger than 96" and in one piece, will have a 2% upcharge applied and must be approved by production.



CANTILEVERS

- The standard color for cantilevers is black unless otherwise noted and are sold in sets.
- If there are no wing panels in the design, then the black cantilevers will show and will not project an acceptable appearance.
- Therefore, cantilevers are offered in the standard colors with a minimal increase in price.
- Please use the proper color in the sku #.
 - Please use these when selling 1 cantilever.
 - CANTA2L
 - CANTA2R
 - CANT30A2L
 - CANT30A2R
- Single (CANTA2L/CANTA2R, CANT30A2L/CANT30A2R) cantilever SKU's are to only be used when replacing a cantilever on a work surface (painted to match trim).
 - If the customer wants to order additional cantilevers then you must use the CANTSET30A2 or CANTSETA2 SKU's.

GROMMETS AND DATA PORTS (FLPDM)

- Extra grommets carry a cut charge
- If a customer orders our data box there is no extra charge for the cut
 1. Data Port SKU is FLPDM
 2. Grommet Cover Only SKU is GR
 3. Grommet Cover & Cut SKU is GRCUT

LAMINATES - CUSTOM EDGE

SELF EDGING

- OPS can do self edging but we do not recommend it.
- There is no extra cost for this if using Wilsonart, Pionite, Formica, or Nevamar.
 - If using an OPS standard finish then a 2% upcharge applies.

CUSTOM EDGING

- Notify purchasing if a sales order contains custom edge banding, there may be an upcharge.
 - Please check every time as the cost may change.
- If the order requires less than 2500 ft. of banding, there is a \$150 set up fee and the per ft. cost is .24.

PROCESSING EDGE BAND/T-MOLD ORDERS

- Have the color follow the edgeband/tmold (Example EDGEBAND.HF) when typing the sku.
- Sell at .45 per foot for the both t-mold and edgeband colors we stock (HF, HT, BU, LT, JT, MT)
 - Any additional color requests will need to be quoted through purchasing mgr.
 - Edge band pricing:
 - 1 to 200 feet of edge band .45 cent a foot
 - Over 200 feet of edge band .34 cent a foot
 - Over 1000 feet of edge band .25 cent a foot

WORK SURFACE SUPPORT PANELS

WSSP

- WSSP24 or WSSP30 use 8 sq ft
- If we offer a work surface support panel in a laminate finish, it is a 2% upcharge
- Waste fees would apply if they are using less than one board worth of panels



WOOD GRAIN WORKSURFACES

- For each order that the laminate is a wood grain, the dealer will need to choose if they want the grain to be OPS standard (option 1) or for a 1% list upcharge the grain follows the flow of the station (option 2).
 - Option 1 or option 2 should be identified on the order in the work surface drop down box (ex Henna Cherry – 1 or Henna Cherry – 2) anytime option 2 is chosen the 1% upcharge should be reflected on the line item (the work surface returns).
 - This applies to OPS standard laminates as well as any custom wood grain.
 - **SEE GRAIN RUN SHEET**
- + Peninsula Tops - The maximum size we can cover using Option 2 is 60"

FLIPPER DOOR LAMINATES

OPS Signature Finishes: BU, WF, SHADOW RIDGE, EMPIRE MAHOGANY	4% Upcharge
OPS Work surface laminates – MT or BU WS Trim only	4% Upcharge
Custom Laminate: Nevamar, Wilson Art, Arborite, Formica	TO BE PRICED BY PURCHASING. PRIOR TO QUOTING. THERE MAY BE A WASTE FEE
Custom Laminate: Plonite	TO BE PRICED BY PURCHASING. PRIOR TO QUOTING. THERE MAY BE A WASTE FEE

- Laminate Flipper Doors: Must use "A" style door with "B" style shelf.
- Laminated doors are thicker than metal and the A01 lock housing is not long enough, so you have to use a lock2 which requires "B" style shelf.
 - You can choose to have "A" or "B" style shelf ends, just add in as a line comment.

NOTE: "A" style shelves are sold as "remanufactured" only. New "A" style shelves are not available.

SHELVES

DISPLAY SHELVES

- The shelf part has to be a style because they are flipped and the lip underneath is used.
- The shelf ends can be either a or b style.

EDP SHELVES

- Always review availability and lead time with production before ordering.

KEYS

FLIPPER DOOR KEY ALIKE PROCEDURE

- NOTE: We cannot key alike A style flipper doors with FP peds ONLY with SP peds.

ORDER ENTRY/CSR

- Orders with "B" Style FDUs and Key Alike - add a comment under each FDU line stating "Key Alike Order"
- Enter the LOCK2. **.KA part number and quantity of total locks OPS needs to send your key alike comments should include ALL items being keyed alike.
 - Add a discount line on the LOCK2 line "LOCK CREDIT"
 - Apply discount for flipper door quantity only
- When keying alike "A: Style FDUs, you will enter as normal charging for each lock core with standard notes.
 - If selling lock cores of any types as a part item/fee's apply.

NOTE: When placing orders B style flipper doors but not asking for key alike, production will ship the flipper door with the core installed in the flipper.

PRODUCTION

- When the job is entered, the same comment must go on the job alerting the Flipper Door Department that the cores will need to be removed.
- Once the flippers are assembled, the core needs to be pulled out. these will be put back in the bin with the key alike cores.
- Cores for the flippers will be packaged in individual bags with the cores for the pedestals or lateral files.
- On orders that are not Key Alike, the core will remain in the flipper. If flippers are shipped without cores a Change Key will need to be supplied with each order.



KEY EXAMPLE



Quote

Quote#: 32758
Page: 1 of 1

4700 Deepwater Terminal Road
Richmond, VA, 23234
Phone: 804-275-2468
Fax: 804-275-2329

Job Name: KEY ALIKE SAMPLE

Quote To:
0174 Open Plan Systems
Gold 4700 Deepwater Terminal Rd.
Richmond VA 23234
USA

Open Plan Systems
4700 Deepwater Terminal Rd.
Richmond, VA 23234

Date:	PO #	Payment Terms	CSR	TM	Ship Via		
11/19/2013		Paid In Full Before Ship	Dina	House	HMUTRK-OB		
Lead Time	Class	Paint	Base	WS Finish	WS Trim	Shelf Paint	Top Cap
	SIG						
Panel Fab	Flipper Fab	Tack Fab	Shelf Style	Elec	Rails		
Qty	Part Number	Description	Disc %	Unit Price	Net Price	Extended Price	
3	FDU3612B	36 x 12 FLIPPER DOOR UNIT - B STYLE	83.00%	\$0.00		\$0.00	
<i>Comments: KEY ALIKE</i>							
3	FDU4812B	48 x 12 FLIPPER DOOR UNIT - B STYLE	83.00%	\$0.00		\$0.00	
<i>Comments: KEY ALIKE</i>							
3	BBF-FP	BOX, BOX, FILE, FULL PULL 23"D NO TOP	83.00%	\$0.00		\$0.00	
3	FF-FP	FILE, FILE, FULL PULL 23"D NO TOP	83.00%	\$0.00		\$0.00	
12	LOCK2.R.KA	LOCK ONLY - FULL PULL / B STYLE FLIPPERS	83.00%	\$0.00		\$0.00	
<i>Comments: KEY ALIKE 3 STATIONS - EACH TO INCLUDE (1) BBF-FP (1) FF-FP (2) FDU B STYLE</i>							
<i>* NO CHARGE FOR FLIPPER DOOR LOCK CORES</i>							

Order Charges:

Our goal is to provide the best service possible to meet our delivery needs.
Please complete the below form to submit any special shipping requests.

www.openplan.com/shipping-form

EXPANDED SEATING LINE!

<http://www.openplan.com/elevation-series-seating/>

Contact your CSR for additional information.

Open Plan, Open Minds. Buy Open Plan Systems

Verification of all specs and drawings is the sole responsibility of the dealer for whom this quote was generated. OPS will provide connector vhf drop downs and in line drop downs if the requirements are provided at time of order *

LIST TOTAL: \$0.00
SUBTOTAL: \$0.00

Tax is not included on Quotes, but as required, 5% Tax will be included on the Order.
** Quotes valid for 30 days **

EXTENDED TOTAL: \$0.00

Accepted By: _____ Date: _____

1. Order Approval Process: Prior to orders \$2,500 or over being entered into production status, OPS requires a customer signature or e-mail authorization, approving the order acknowledgement. 2. Freight charges / Claims / Punch list Fees: Per OPS published shipping schedule. 3. Customers must be in good credit standing and deposits received 48 hours prior to scheduled ship date to avoid rescheduling. 4. Storage Fee: Customer orders stored 30 days beyond the ship date are subject to a storage charge of 5% per month. 5. Cancelled orders policy: For orders utilizing our standard finishes and fabrics as advertised in our fabric and finish material listing: Orders are final and binding however: a. Orders cancelled within 48 hours may be cancelled at no charge. b. Orders cancelled after 48 hours but prior to order being put into production status are subject to a 15% fee of order value for restocking of fabrics, raw goods and pre manufacturing expense. c. Orders cancelled once order has entered production status are subject to 25% cancellation on pedestals and connectors and 50% on all manufactured items. d. Orders in non standard fabrics or finishes are not subject to cancellation. 6. Return Policy: Products returned within 30 days after ship / pick up date are subject to restocking charges of 50% on all items plus transportation both ways. After 30 days from ship / pick up date product may not be returned for credit. 7. 1 Week Program Policy: Once order is placed, revisions and cancellations are not applicable. Order will be auto-approved for production. *Terms: Net 15 to qualified accounts

KEYS

*Keys ship with no freight charge



LOCK2.R.KA	Key alike Full Pull Peds and Laterals. Line comments on order must identify what the key alike is for. If flippers are to be keyed with square pull, add a line comment "B" style. If "A" style - must contact Hugh and there may be a possible upcharge. \$35.00 LIST
LOCK2.U.KA	For Square Pull cabinets. If flippers are to be keyed with square pull, add a line comment "A" or "B" style. \$35.00 LIST
LOCK2.U.KA	Keying alike flipper doors only, add a line comment whether the FDUs are "A" style or "B" style. \$35.00 LIST
CK.R	Change key, \$35.00 LIST
CK.U	Change key, \$35.00 LIST
MK.R	Master key, \$35.00 LIST
MK.U	Master key, \$35.00 LIST
KEYS	\$5.00 net cost per key, include line comment for key number.
LOCK1	Complete assembly for "A" style FDU. Includes: core, housing, keys, nut for housing, trim ring, latch and screw for latch. Only specified when a complete assembly for "A" style doors. \$35.00 LIST
LOCK2	Complete assembly for "B" style FDU, square pull peds and full pull peds. \$35.00 LIST

*Includes: core, housing, keys, latch, screw, washer and lock clip to hold housing in place. Only specified when a complete assembly for "B" style FDU doors, square pull or full pull peds and laterals.

NOTES:

1. A chrome core front on an "A" style FDU is the old lock core with no extension. This would only be on "A" style flipper shipped before 2010. Pedestal type drives the SKU#. Refer any questions to Hugh.
2. When a customer is requesting to key alike something that has already shipped, make sure that we are providing the previous sales order number so that production can confirm what they are pulling (e.g. SP / FP).
3. When a customer is requesting a key alike, cores that are numbers 200 to 299 are square pull pedestals and lateral cores. Full pull are numbers 226-326. Items are randomly keyed in product before shipping. We do not offer a current in-house key alike, the customer can order the key alike. When this is done we will send a change key and a master key at no charge as well as we will offer a return with a 25% restock on the returned cores and dealer will have to pay freight.

SEATING

SEATING DISCOUNTS SEATING FALLS UNDER THE SIGNATURE CLASS



- In-stock seating: Dealer levels - 67% discount.
- GSA (only chairs not on our GSA Contract), Retail, National Account levels - 55% discount.
- Select GSA Chairs on GSA Contract- 65.1%
- Stock chairs ship in 1 week.
- Sample/Show Room chairs receive an additional 25% discount.
- OPS 3119 and the OPS 3159 chairs:
 - These chairs are packaged as a set of 4 and we should encourage our dealers that in order to show the stacking capability of the chair they should order all 4, also we will extend the 25% sample chair discount to ALL 4 chairs, cannot break box
 - Standard freight applies/limit 1 style per year.
- SPECIAL: OPS 4008 CHAIRS - Purchase 20 or more – SPECIAL PRICE OF \$130.00 EACH. OFFERED TO ALL DEALERS
- OPS9838D comes in box of 2

NOTE: When we are changing fabric of OPS4008, we need to use OPS4008.F



APPROVAL PROCESS

- All orders that are over \$2500, an approval link is sent to the customer to view the order and click "Approve" or "Reject" if something is incorrect.
- From the time the link goes out, the customer has 48 hours to approve the order to ensure they keep their ship date.
- If a revision is made and needs to be forced out to the customer immediately, you need to email the Customer Service Manager and the Sales Administrator to have the link resent.
- If a revision is made to an order that is over \$2500, but it is an in-house revision and you do not feel that the customer needs to re-approve, you will need to send a detailed email to the Customer Service Manager and the Sales Administrator for the order to be reviewed and / or forced to an Approved Status.
- Currently the link is being sent out once a day unless requested.
- If a revision is made to change product after it has been approved, a \$50.00 revision fee applies.

AS IS PRODUCT

- Please allow a 2 week lead time for AS IS product. We have to allow production time to pull the product.
- Peds are cleaned and keyed. Work surfaces have to be checked for damage and then cleaned and prepped for shipping.
- Before ordering "As Is" product, verify inventory with Production to make sure that what is in stock is of resalable quality

TRIM REPLACEMENT

- If one side of WS trim is bad, we will replace that one side.
- If 2 sides are bad then we will replace all of the WS trim.

CANCELLATION POLICY

- Orders canceled within 48 hours may be canceled at no charge.
- Orders canceled once the order has entered production status are subject to a 25% cancellation fee on pedestals and connectors and a 50% fee on all manufactured items.
- Orders in non standard fabrics or finishes are not subject to cancellation.
- When requesting an order to be canceled, follow the steps below for canceling an order.

STEPS FOR CANCELING A SALES ORDER:

1. Customer sends CSR a cancellation request.
2. CSR's are to contact Sales Assistant to see if the order can be canceled and what fees would apply if any.
3. The CSR is then responsible to inform the customer of any fee's from production and get a final approval for the cancellation and fees.
4. Once the customer has approved the cancellation the CSR's are to e-mail CSR Manager / Sales Assistant and Sean with the request along with the final approval from the customer.
5. Sales Assistant will then change the Order Ship Date to the designated HOLD date (12-31-2013).
6. Sales Assistant will then send an e-mail to All Production Managers to notify them of the cancellation *Please include Order # & Original Ship Date *
7. Production / Sales Assistant will then Remove All MRP #'s or Job #'s associated to that order.
8. Production will then e-mail AR to have the order canceled and inform them of any fees associated with the order (Fabric, Paint, Laminate, Restocking Fees etc.).
9. AR will then e-mail production & Sales when the order has been deleted & fees applied.

CUSTOMER PICK-UPS

CUSTOMER PICK UPS

- Anytime you are doing a CPU for a customer that is NOT from VA; you need to list the ship via as Customer Carrier; not CPU.
- CPUs, because they are taking possession of product in the state of VA, must pay VA sales tax unless they have a tax exempt certificate form in Va.
 - Customer install in the state of VA is taxable, no matter who is paying for it. If they are possessing the product in VA, VA sales tax is to be applied.



SHIPPING FEES



DESCRIPTION	FEE	NOTE
Lift Gate	\$250	Not offered on 53' truck. MUST be approved by Shipping Manager prior to submitting the order
Notification	\$50	24 hour call ahead should be added to header comments and charged as a miscellaneous header charge.
After Hours Delivery	\$100	Fee added as a miscellaneous header charge with a header comment. After hours delivery must be approved prior to the order being placed.
Rush	5% or minimum of \$25	Of total net price. Sales Order must have the standard ship date w/ rush fee applied to orders a miscellaneous header charge. Fill out the lead time request form w/ request date and attach to the front of order.
Revision	\$50	Added to order as a miscellaneous header charge when a change is made by customer and the order is in production.
NSD	3% of total net or minimum of \$25 Waived on dedicated trucks	Add as a miscellaneous header charge with a header comment : 3% NSD fee added. Must be approved by Shipping Manager to ship on NSD.
Time Delivery Insurance	\$100	Add as a miscellaneous header charge with a header comment. Form must be attached to order. A timed delivery option is only offered on a dedicated truck

NOTES:

1. **Anytime you are doing a 24 hour call ahead, lift-gate or any special shipping charges, the charge goes under the misc header and you MUST provide a header comment AND MUST BE COPIED TO THE PICK/PACK TAB.**
2. **All shipping request to be approved by Barry.**

TIMED/SCHEDULED DELIVERY POLICY:

1. In order to accommodate our business partners' needs and provide superior service OPS, LLC announces our delivery appointment policy.
2. This policy has two objectives: have product on site when required and avoid additional financial liability for all parties.
3. We will make every effort to deliver a truckload (\$50,000.00 NET SALE or APPROVED) to the address provided with the following restrictions:
4. WE CHARGE A \$100 FEE FOR A DELIVERY APPOINTMENT
5. We require a two hour time window to accommodate factors out of our control-(traffic or other road conditions).
6. Inclement weather will increase this window and we will advise for this situation on a case by case basis.
7. We will not accept financial responsibility for late deliveries or circumstances beyond our control other than as stated on our Appointment Contract. WE WILL WAIVE THE \$100 APPOINTMENT FEE IF WE ARE LATE.
8. We require a cell phone contact of a responsible party who will be available after regular working hours so we may notify them of issues affecting the delivery. We will notify you of issues by two hours before the scheduled appointment.
9. We will provide an after hours contact from OPS, LLC.
10. We will call you 48 hours before the delivery to confirm addresses, contact information and scheduled delivery times.

SHIPPING

ESTIMATED SHIPPING SCHEDULE

Punch Request	2 Days
Chairs, Peds Connectors & Parts	1 Week
Quick Ship	2 Weeks
C2	3 Weeks
Signature	3 Weeks

NOTE: When delivering directly to a job site, the dealer must understand that it is the responsibility of the individuals receiving the product to remove it from the truck unless stated on the order and an additional fee is charged. This fee is determined on a case by case basis.

OVERNIGHT REQUEST:

If a dealer would like to have something sent overnight, they will have (2) options:

1. They can provide us with their freight account number and the freight company and we will bill all charges to their account.
2. If they want us to charge it to OPS's account and bill them, we will get a quote from shipping for the overnight charge.

NOTE: This fee that shipping gives you will include an upcharge of 15% you will not need to disclose this to the customer you will just need to let them know the freight charge that will be applied for OPS sending it overnight.

STORAGE FEES:

- OPS allows 30 days of free storage beyond the scheduled ship date.
- Storage fees can be avoided by revising the sales order to change the ship date prior to production.
- To change the ship date after the order has entered production, a request must be made to the CSR Manager to change ship date.
 - This is logged in to establish the start of the 30 day free storage period starting the date of the original ship date. A request is sent to Director of Operations to change the ship date and the sales order is revised to the new date.
- Once the date is changed, the CSR Manager will track to see when and if storage charges apply. If storage charges apply a monthly request is sent to accounting to invoice.
 1. SHIP DATE CHANGES **MUST HAVE** written approval from the director of operations/production.
 2. A STORAGE FEE of 5% of the net each month or can pay in full. Hold for 60 days with no fee.



SHIPPING FORM

OPS CUSTOMER SHIPPING FORM

Order Number _____

DELIVERY OPTIONS:

All options must be approved by shipping.

Job Site OPS Delivery

** Must have valid contact information for location that driver will contact 2 hours prior to delivery. Customer is responsible for unloading.

Delivery Appointment

** Only available for orders greater than \$50,000 Net
** Insurance policy; for a cost of \$100 you can guarantee delivery with in a 2 hour window. If missed, a Credit of \$32.50/Man Hour (Max of 6 Hours for \$585)
** If additional coverage is required please contact your CSR for a quote.

OTHER SHIPPING OPTIONS:

All options must be approved by shipping.

NSD - Non Standard Delivery

3% Net Order or \$25

Rush

5% Net Order or \$25

After Hours Delivery

\$100

24 Hour Notification Call

\$50

Lift Gate

\$250

CUSTOMER INFORMATION

Delivery Address _____

Customer After Hours Contact _____

Date _____ Phone Number _____

Number of Installers on Site _____ Arrival Date / Time _____

Customer Initials _____ Printed Name / Title _____

* By Initialing this form, you consent to the understanding that your initials represent your Signature of Agreement

Additional Comments:

Submit to your Customer Service Representative

SUBMIT TO T1

SUBMIT TO T2

SUBMIT TO T3

SUBMIT TO T4

FOR OPEN PLAN SYSTEMS ONLY

Shipping Manager Signature _____

Date _____ Phone Number _____

Driver Name (Printed) _____

Date _____ Phone Number _____

DELIVERY CONFIRMATION

Driver Signature _____

Date / Time _____

* Open Plan Systems will not be responsible for any delivery that does not meet the above requirements based on weather or uncontrollable situations, and will credit back the initial charges.



