

XPAND REACH

Conference Table – Assembly Instructions

Tools Required



Cordless Drill

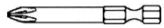

Phillips bit with extension
for Work Surface screws
(XP-Screw-WS)



3/16 Hex drive bit
for XP-Screws



Measuring Tape



Level





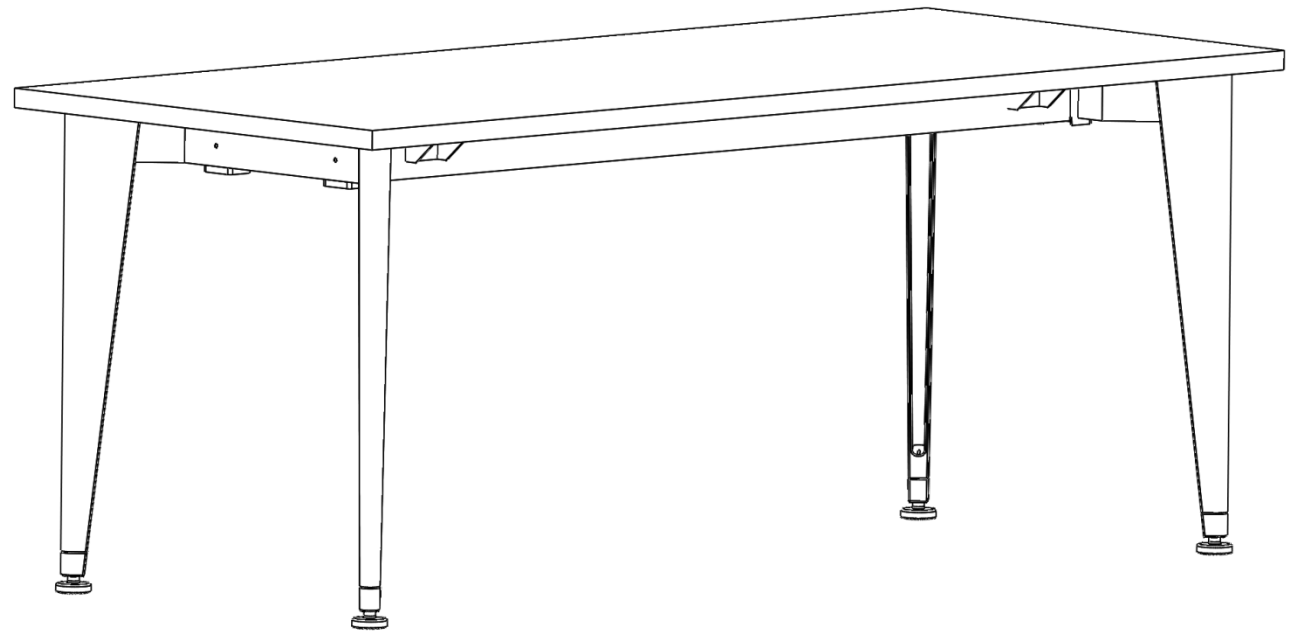



Rubber Mallet

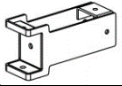
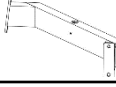

For additional assembly support, refer to www.openplan.com
or contact 844.OPS.OPS1

XPand Parts Used for Assembly

Item	Part name	Part Description	Image
1	XP-LA	Leg Assembly	
2	XP-SB-Bracket	Stretcher Bar Bracket	
3	XP-45D-XX-TL	45 Degree Table Leg Rail, XX"	
4	XP-WSSB	Work Surface Support Bracket	
5	XP-SB-XX	Stretcher Bar, XX"	
6	XP-SCREWS-WS	10-9X1 PH Pan Head, ST P'bd Screw, ZP	
7	XP-SCREWS	5/16-18 x .5" Hex Socket Cap Screw, FT, SS	
8	XP-TXXXX	Work Surface	

XPand offers two types of end legs, Tapered legs and Rectangular legs. Though the legs look different, the assembly process is same.



Tapered leg
(XP-LA)



Rectangular leg
(XP-LA-RL)

Step 1: Prepare a large floor space to put the XPand order together. Unpack the parts and check to see if all the XPand parts are present as per the Sales Order pick list.

Step 2: Assemble the Leg Rails (XP-45D-XX-TL) to the Legs using (2) XP-Screws.

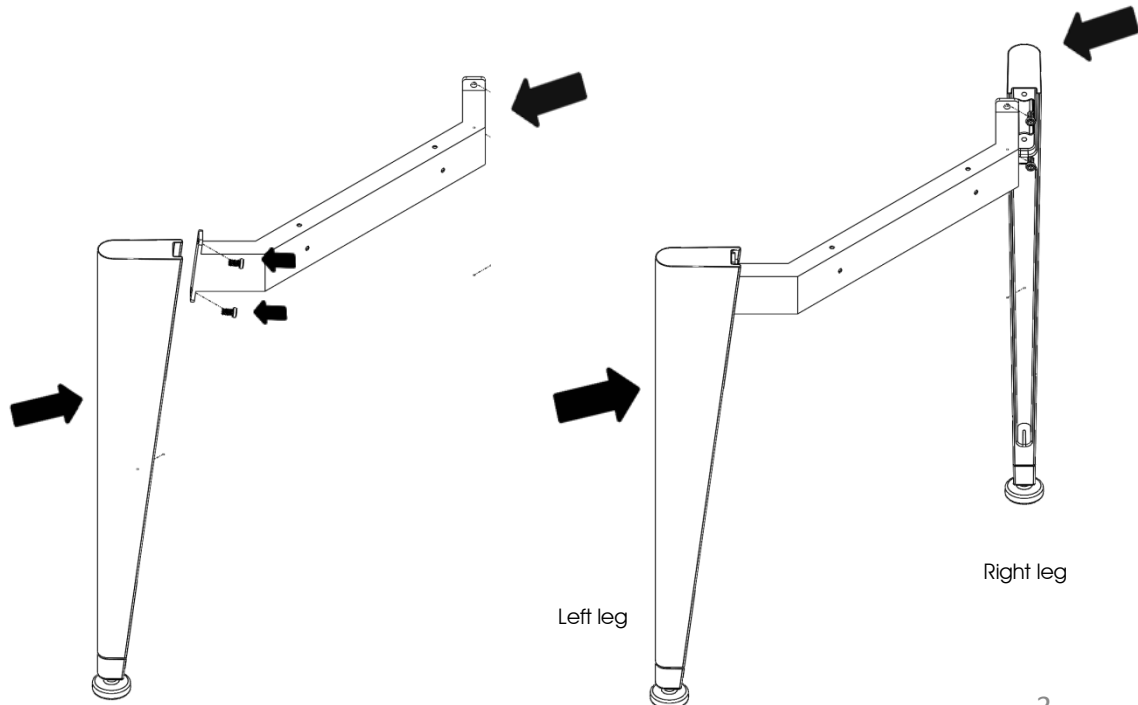

Note: The assembly Instructions are same if straight XP-LR-XX are used in place of XP-45D-TL.

Step 3: Assemble (2) XP-SB-Brackets to the Leg Rail using (2) XP-Screws per Bracket. Make sure the Top Face of the Bracket faces upwards. Figure A shows the Top Face of the Bracket.

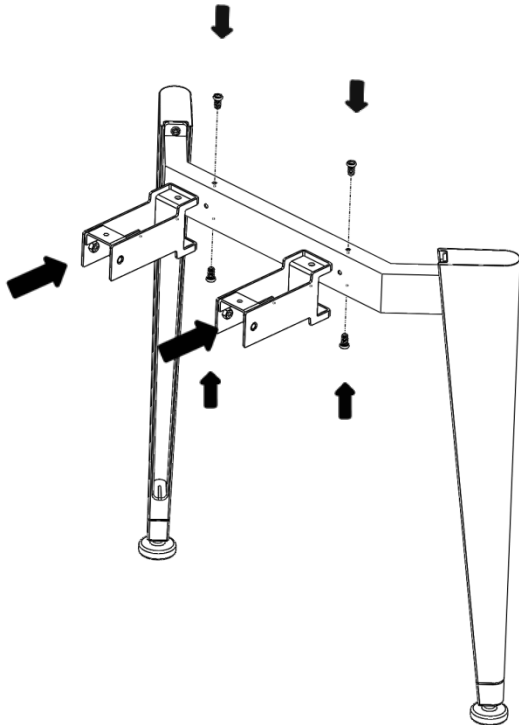

Step 4: Assemble the Stretcher Bars (XP-SB-XX) to the XP-SB-Brackets using (2) XP-Screws per Bracket.

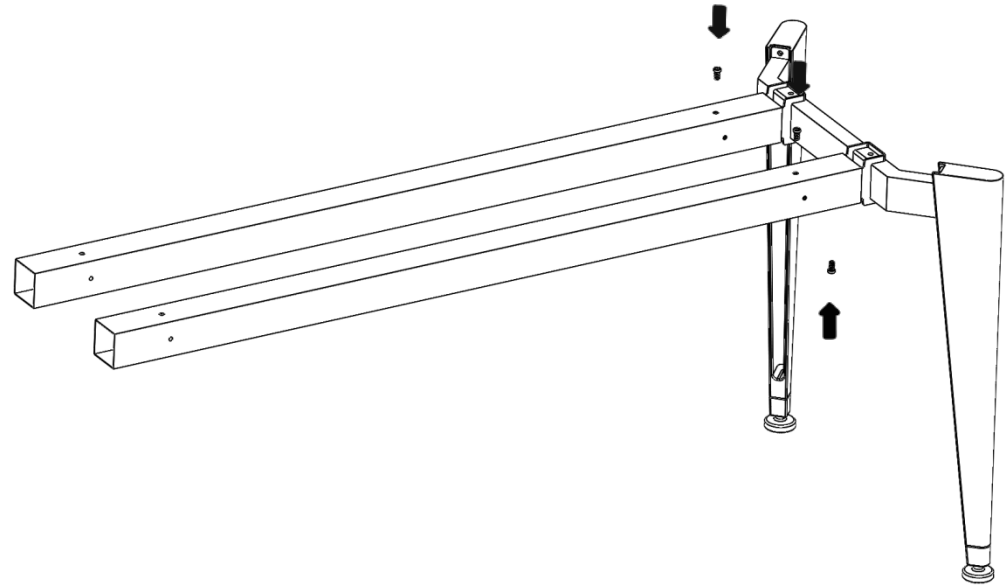

Note: The Stretcher bar is 5" shorter than the specified size. For example, XP-SB-60 is actually 55" long.

Note: If multiple benches need to be ganged, don't attach 2nd End Leg Assembly yet. Attach XP-MLC to the other end of the Stretcher Bar.

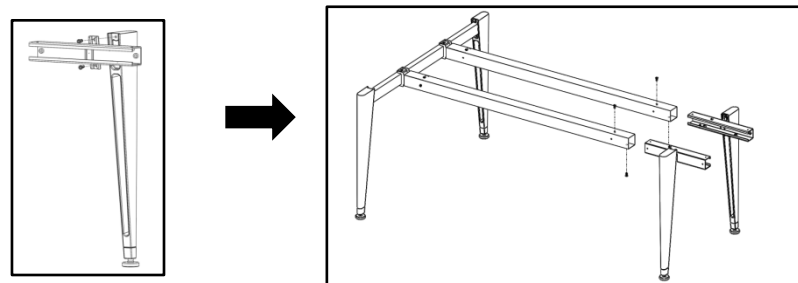
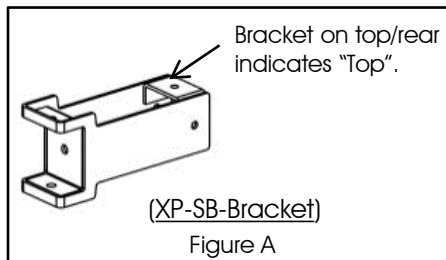

Step 5: Repeat Step 2 through 4 to assemble the other end of Stretcher Bars.

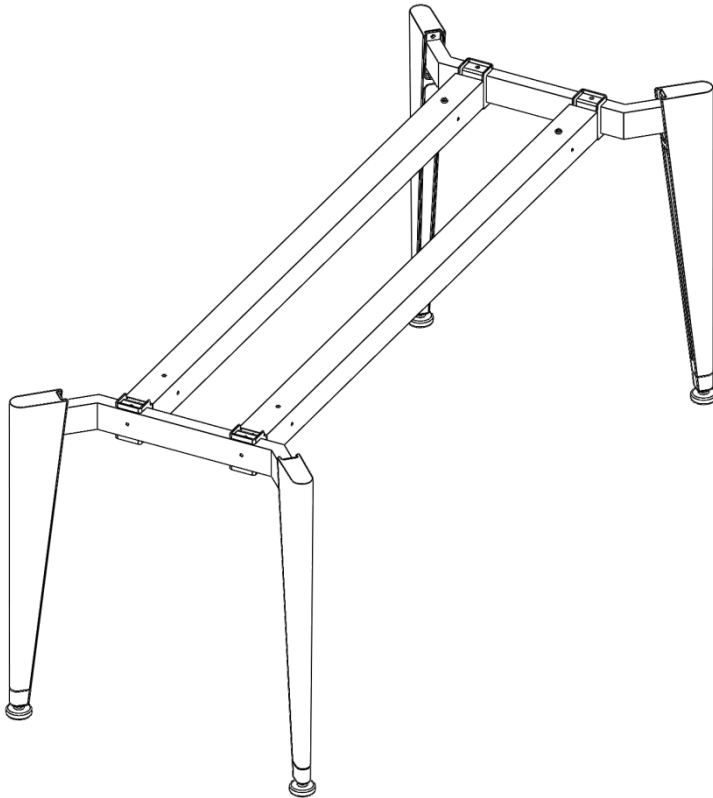

Step 6: Assemble XP-WSSB to the Stretcher bars using XP-Screws as a Set Screw. See Figure B on page 6 for additional support locations.

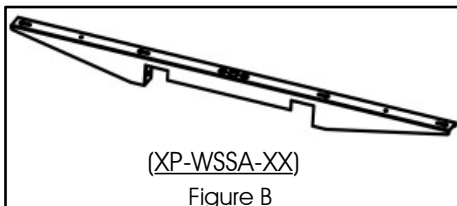
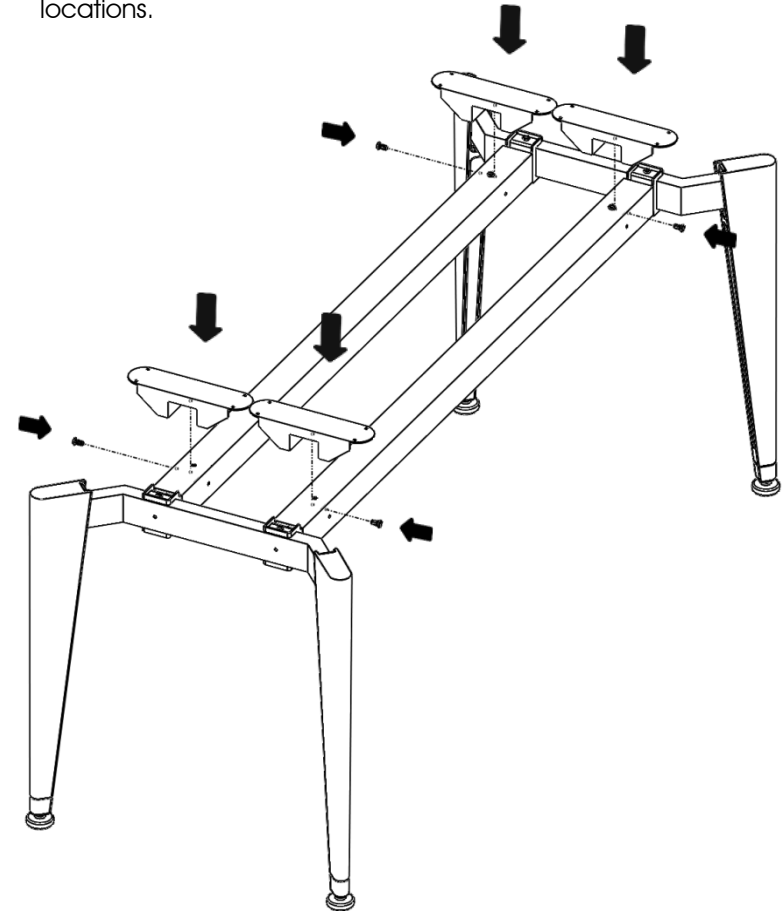

Note: When 48" (XP-45D-48-TL) or 60" (XP-45D-60-TL) leg rails are used, XP-WSSA-XX is used in place XP-WSSB.

**Note:**

Figure C shows the number of XP-WSSB's assembled to Stretcher Bars of different lengths.

Step 7: Center the Work Surface on the frame and secure the Work Surface to XP-WSSB's using (4) XP-Screw-WS per Bracket.

Step 8: Level the Conference Table unit by turning the leveling feet.

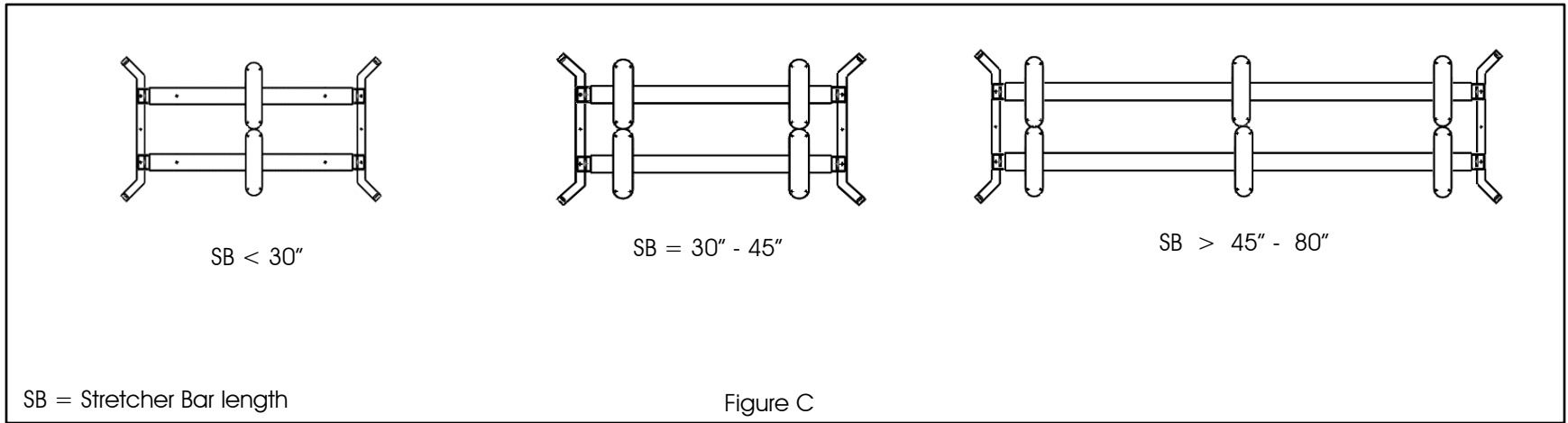